

DOMUSLIFT®





DOMUSLIFT®

::: Free from stairs



DomusLift is the elevator designed to meet your vertical mobility needs in both public and private buildings.

It is the ideal solution for elderly and impaired people who gain independence and freedom from stairs.

It enhances any environment and thanks to the special Light-Touch by Giugiaro and Classic models, adds exclusive style and elegance.

With a wide range of accessories and finishes, as well as the S-Small and XL versions (designed respectively for small spaces and the need for a larger car) make DomusLift ideal for any need.

DOMUSLIFT®

- Quiet and easy to install
- Power consumption like any household electrical appliance
- Connects to any electrical outlet
- Requires a small space
- Removes architectural barriers
- 3-year warranty
- Is available in 36 models, indoor and outdoor

www.domuslift.com

⋮ Elegance and style



Being elegant, quiet and discrete allows DomusLift to perfectly fit any environment, new or existing.

The elegance of DomusLift is created by the sleek anodised aluminium structure and the standard panoramic glass door which provides optimum light and visibility.

It is truly a modern product, designed and manufactured to meet a wide range of needs and tastes. From the garage to the roof, DomusLift moves effortlessly up to five floors.





Masonry shaft

DomusLift can also be installed within your house. It serves period and modern buildings without affecting their style.



NEW – Special Version with 55-mm pit

(2520 mm headroom)

Technical data

Travel	max 12 m
Pit	min 100 mm upon request: 55 mm
Headroom	min 2450 mm
Rated load	250 Kg
No. of stops	max 5
Speed	max 0,15 m/s
Rated power	1,1 kW running current
Supply voltage	230 V single-phase

⋮ A user-friendly home



Easy

DomusLift quick installation procedure requires minimum masonry work due to the car being supplied with walls on three sides as standard.

The installation also needs limited regulatory approval and also benefits from low energy consumption by using the normal household 230v outlets.

Safe

With the car being fully enclosed on three sides and the use of internal photocell sensors, passenger safety is always guaranteed. An operating key is located on the push button panel to prevent unauthorised use. In the event of a complete power failure the car is automatically brought to a landing allowing passengers to exit in safety.

Accessibility

DomusLift is an affordable solution with accessories ideal for those with impaired mobility or special needs. The push button control panel is located at a comfortable and accessible height. The remote control provides full operation of the powered door opening and the landing calls. The XL version was conceived and designed to provide you with greater space and load if required.

Reliability

We are confident to provide a three year warranty.



Aluminium shaft

DomusLift travels inside a robust and elegant aluminium structure, called shaft structure.



Power unit

The standard controller is provided in a special cabinet of small dimensions (600x280x1000mm). It can be easily concealed in the cellar or garage, because it can be installed up to 7 metres far from the DomusLift.



⋮ Functionality everywhere



Public areas

Thanks to DomusLift, shops and restaurants, shopping centres, offices, hotels and factories offer easy access to all levels. Easy and quick to install DomusLift is the ideal solution for complete mobility within public and working areas. The wide choice of models and features enables DomusLift to meet any requirement within a new or existing building. Installation flexibility, large service capacity and elegant aesthetics are just some of the DomusLift key features.



In the case of existing buildings with especially reduced and tight spaces, the DomusLift is the ideal solution.



Outdoor

DomusLift can be easily installed outdoors. It requires minimal masonry work without effecting the architectural context and integrity of the building whilst offering easy access to all floors. The all aluminium structure can be painted and finished to compliment the building and provide durability.



High-Tech Design



The DomusLift elegance is now further enriched with Giugiaro Architectura Design innovative lighting system, creating new in car environments and atmospheres and the subtle sophistication of the touch screen control panel.

lighttouch

by

GIUGIARO
ARCHITETTURA



Classic style



The DomusLift Classic range is designed for those who love the warmth and natural beauty of wood. The "wood effect" is obtained by a special painting method upon the aluminium structure.

classic



Aluminium door and structure with cherry "wood effect" special painting.
Golden handles and pushbutton panels.
Resin floor and "Floral" lighting.



High-class decor



High-class decor and innovative materials and design create the most aesthetically exclusive personal elevator by combining IGV technology with Bisazza style.

luxury collection

by

BISAZZA

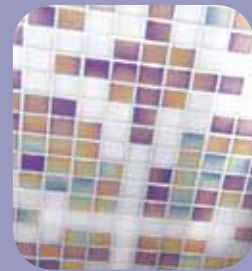

Special versions

A special selection of materials and surfaces were especially conceived and chosen to make each and every DomusLift a special place. In fact, our special range of exclusive finishes meets the requirements of even the most discerning customers.

NEW

LED backlit walls for a unique atmosphere, or customise with one of your favourite pictures.

Only available for 800 mm walls, push-button panel wall excluded.



NEW - Resin walls and floor

Inner surfaces can be customised with special resin allowing you to choose the background colour and design or to insert art images and designs. These panels are exclusive to DomusLift and are manufactured to the highest craftsmanship.

Pushbutton panel excluded.



Example: drop-effect painted wall



Example: floor / wall painted with leaf effect



Example: floor / wall with sand

Colours and accessories

The colour of the original material may differ from that shown below

CAR WALLS

Skinplate



Coated chipboard

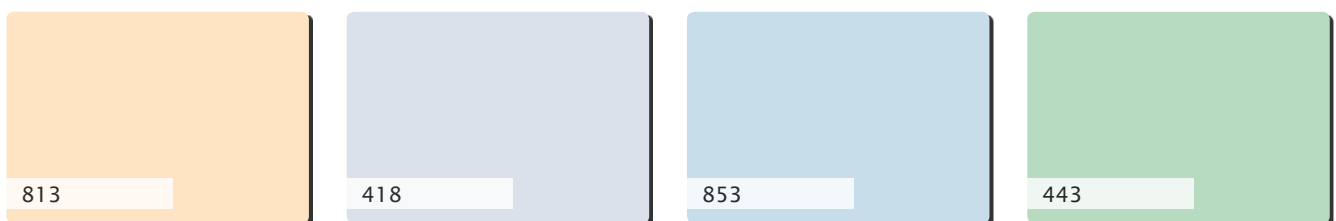

Plastic laminate



CAR WALLS

NEW - Botanic Line - Plastic laminated

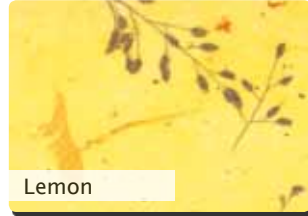

NEW - Pennystone Line - Plastic laminated with copper inserts



Frost Line - Silver



NEW - Spark Line - Plastic laminated with aluminium inserts



NEW - Resins - Colours and processing highly customisable

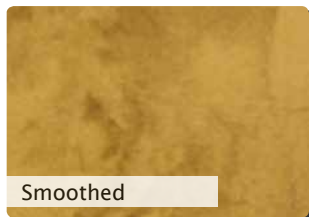
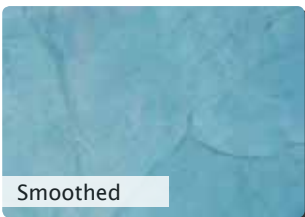

Stainless steel

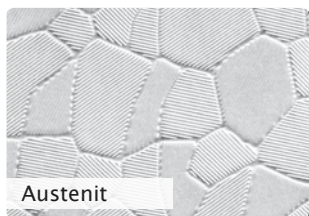
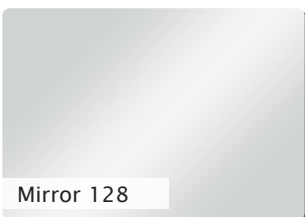

Colours and accessories

The colour of the original material may differ from that shown below

CAR WALLS AND SHAFT STRUCTURE

Glass



Serigraph effect



Coloured



Milk white



Transparent



Bronze Stopsol



Mirror



NEW
Self-cleaning glass
 A special covering for outdoor applications promote:
 - break up of organic material under the effect of sunlight
 - greater water run off removing dirt.



NEW
Photovoltaic cells in safety stratified glass.
 Full design freedom for glass measures, transparencies or colours.
 Only for outdoors.

CAR LIGHTINGS

Floral



Firmament



White



Black



Spotlights



NEW
 Led lighting

CAR PROFILES, DOORS AND SHAFT STRUCTURE

Aluminium - Standard

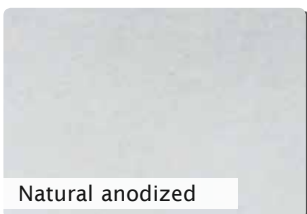

Natural anodized

Aluminium with wood effect painting



Cherry



Deco style white

CAR PROFILES, DOORS AND SHAFT STRUCTURE

RAL

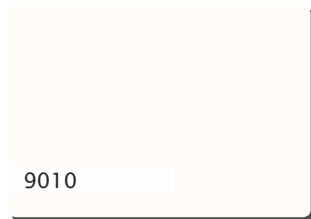
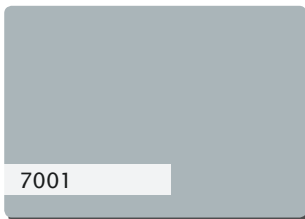
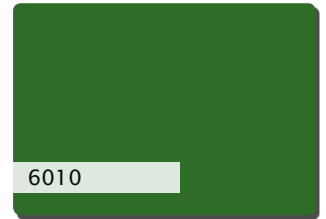
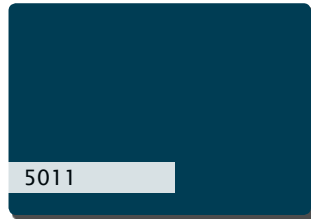
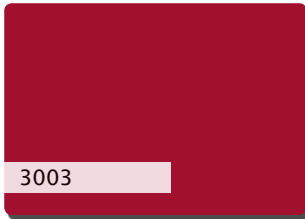

CAR FLOORS

Granit

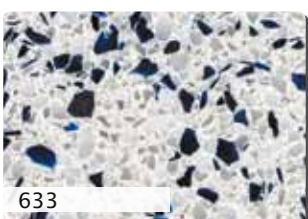
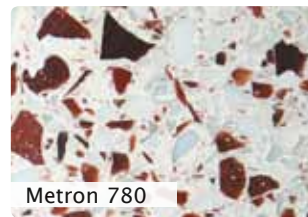
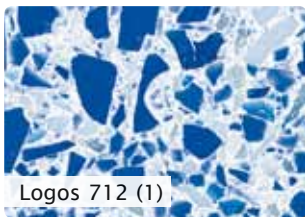

Linoleum

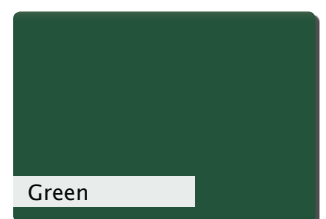
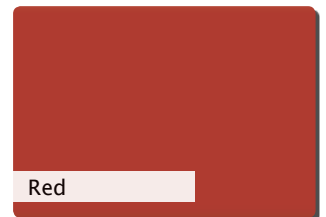

Rubber

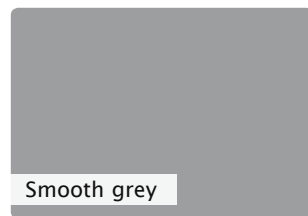
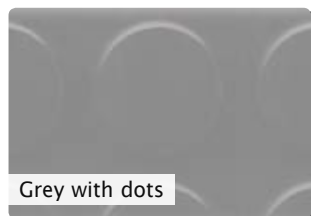
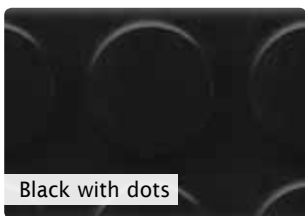

NEW - Resin

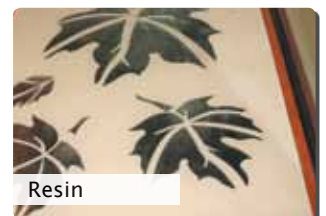

Marmoleum

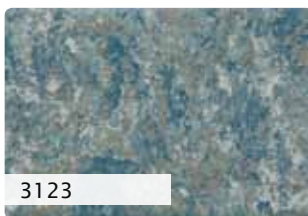
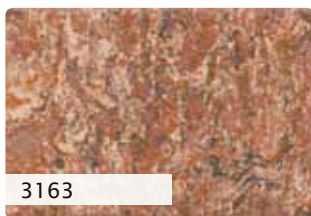
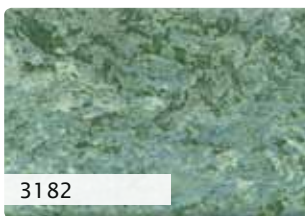

Colours and accessories

The colour of the original material may differ from that shown below

PUSH BUTTON PANELS

Embedded in the round handrail with standard pushbuttons



Embedded in the round handrail with maxi pushbuttons



Handrail integrated

NEW - polish and satin effect



NEW - wood effect



Standard



Maxi push-buttons



Golden



Module



Touch Screen
- only for car



NEW - Tricolor display
- only for Module



HANDRAIL

Standard



Rounded



DOOR HANDLE

Standard



Golden



DOORS



B - PANORAMIC ALUMINIUM

Aluminium profile door with wide glass panels

FINISHES

- anodised aluminium
- RAL painted



C1 - BLIND

Fire-rated doors type:

- C2 - REI 60
- C3 - REI 120

Steel door

FINISHES

- primed
- RAL painted
- coated



D - VISION PANEL

Fire-rated doors type:

- D1 - BELGIUM
- D2 - BS476 - UK

Steel and glass door

FINISHES

- primed
- RAL painted



E - PANORAMIC IRON

Steel and glass door

FINISHES

- primed
- RAL painted



NEW

V1 - PANORAMIC

Total glass door

FINISHES

- stainless steel



Example of aluminium door with special "wood effect" painting, artistic glass, golden handle and pushbutton panel

Aluminium shaft**

Standard models

** Fixing of at least 3 uprights at pit, headroom and each floor level.



DomusLift requires a pit of 100 mm (upon request 55 mm with 2520 mm headroom) or an access ramp. A 2450 mm headroom is enough for a tackle ram system and 2350 mm for telescopic ram.

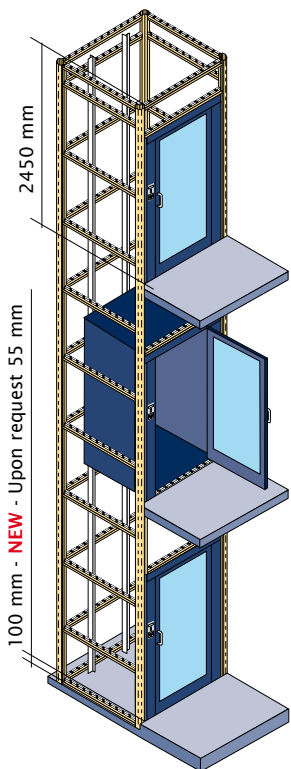

DL-1 C

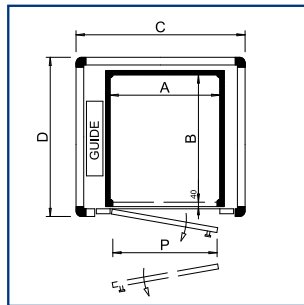

	1C/1	1C/2	1C/3	1C/4	1C/5	1C/6	1C/7	
A	800	800	800	1000	1000	1000	800	Car
B	800	1000	1300	1300	1000	800	1200	
C	1330	1330	1330	1530	1530	1530	1330	Shaft
D	1070	1270	1570	1570	1270	1070	1470	
P	750	750	750	950	950	950	750	Door
Kg	250	250	250	250	250	250	250	Load

DL-1 L

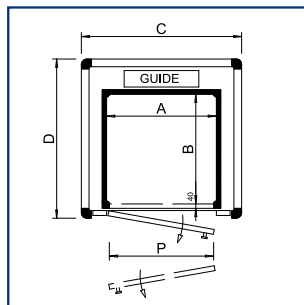

	1L/1	1L/2	1L/3	1L/4	1L/5	1L/6	
A	800	1000	1300	1300	1000	800	Car
B	800	800	800	1000	1000	1000	
C	1250	1450	1700	1700	1450	1250	Shaft
D	1225	1225	1225	1425	1425	1425	
P	750	950	950	950	950	750	Door
Kg	250	250	250	250	250	250	Load

DL-2 A

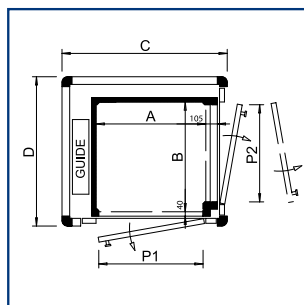

	2A/1	2A/2	2A/3	2A/4	2A/5	2A/6	
A	800	800	800	1000	1000	1000	Car
B	800	1000	1300	1300	1000	800	
C	1290	1290	1290	1490	1490	1490	Shaft
D	1145	1345	1645	1645	1345	1145	
P1	750	750	750	950	950	950	Door
P2	685	750	950	950	750	685	Door
Kg	250	250	250	250	250	250	Load

DL-2 P

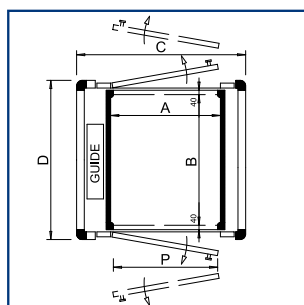

	2P/1	2P/2	2P/3	2P/4	2P/5	2P/6	2P/7	
A	800	800	800	1000	1000	1000	800	Car
B	800	1000	1300	1300	1000	800	1200	
C	1330	1330	1330	1540	1545	1530	1330	Shaft
D	1040	1240	1540	1540	1240	1040	1440	
P	750	750	750	950	950	950	750	Door
Kg	250	250	250	250	250	250	250	Load

The DomusLift lifting platform complies with the Machinery Directive (98/37/EC) and with all essential law requirements.

Accessories:

- fully operational remote control (call, door opening and floor change)
- automatic door opening
- voice synthesiser when stopping at a landing
- car display
- MOX® phone alarm device
- gong (sound signal at landing)



Brick built or concrete hoistway*

Standard models

DL-1C

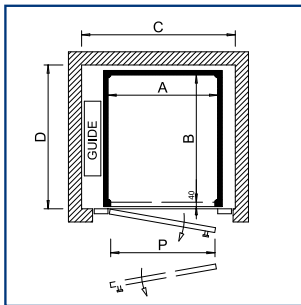

	1C/1	1C/2	1C/3	1C/4	1C/5	1C/6	1C/7	
A	800	800	800	1000	1000	1000	800	Car
B	800	1000	1300	1300	1000	800	1200	
C	1160	1160	1160	1360	1360	1360	1160	Shaft
D	950	1150	1450	1450	1150	950	1350	
P	750	750	750	950	950	950	750	Door
Kg	250	250	250	250	250	250	250	Load

* Clear width between shaft walls.



A wide range is available, with dimensions different from the standard models.

DL-1L

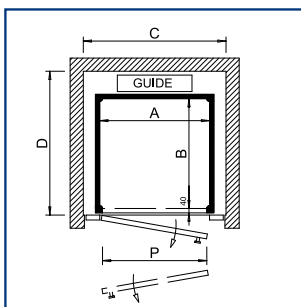

	1L/1	1L/2	1L/3	1L/4	1L/5	1L/6	
A	800	1000	1300	1300	1000	800	Car
B	800	800	800	1000	1000	1000	
C	1030	1230	1530	1530	1230	1030	Shaft
D	1110	1110	1110	1310	1310	1310	
P	750	950	950	950	950	750	Door
Kg	250	250	250	250	250	250	Load



Equipment type-approved to transport impaired persons.

DL-2A

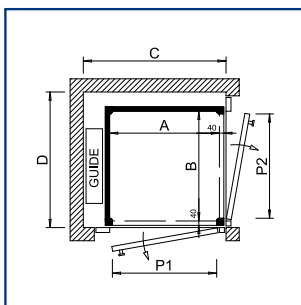

	2A/1	2A/2	2A/3	2A/4	2A/5	2A/6	
A	800	800	800	1000	1000	1000	Car
B	800	1000	1300	1300	1000	800	
C	1110	1110	1110	1310	1310	1310	Shaft
D	980	1180	1480	1480	1180	980	
P1	750	750	750	950	950	950	Door
P2	750	950	950	950	950	750	Door
Kg	250	250	250	250	250	250	Load

DL-2P

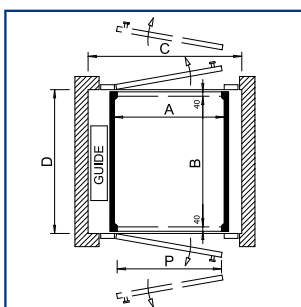

	2P/1	2P/2	2P/3	2P/4	2P/5	2P/6	2P/7	
A	800	800	800	1000	1000	1000	800	Car
B	800	1000	1300	1300	1000	800	1200	
C	1160	1160	1160	1360	1360	1360	1160	Shaft
D	920	1120	1420	1420	1120	920	1320	
P	750	750	750	950	950	950	750	Door
Kg	250	250	250	250	250	250	250	Load

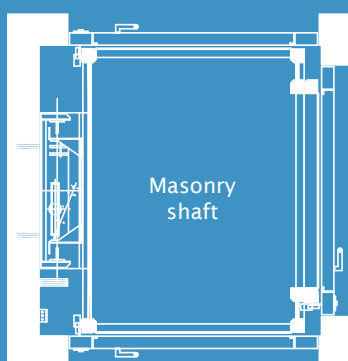
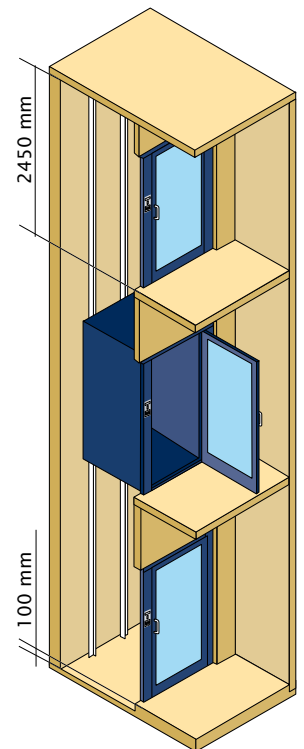

Masonry shaft

Three-access model also available.

Feasibility shall be confirmed by IGV Group SpA technical office.

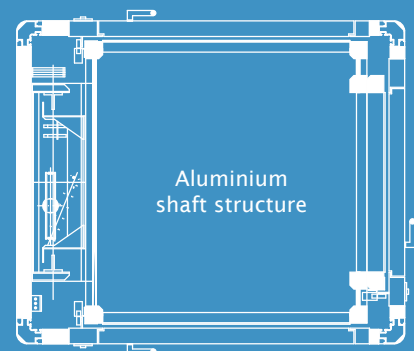

Aluminium shaft structure

DomusLift® S

Ideal for reduced dimension shafts

The **S-Small** series allows the installation of a DomusLift even in the narrowest of shafts. The minimum car dimensions of (up to 580x500mm) guarantee the correct space for a trouble free lift.

With elegant and refined aesthetics the following features are standard:

- walls made of uninterrupted single panel, without aluminium profile;
 - wide range of finishes: plastic, painted and stainless steel laminate;
 - the same accessory range as the standard model, depending on the reduced dimensions.
- Same minimum headroom and pit height.

Masonry shaft

DL-1 C

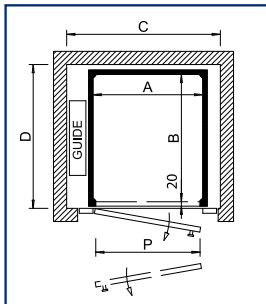

	1CS1	1CS2	
A	800	550	Car
B	800	690	
C	1150	900	Shaft
D	890	780	
P	800	550	Door
Kg	250	250	Load

DL-1 L

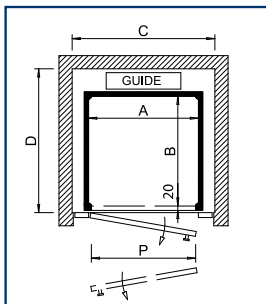

	1LS1	1LS2	
A	800	580	Car
B	800	550	
C	1005	785	Shaft
D	1070	820	
P	800	580	Door
Kg	250	250	Load

DL-2 A

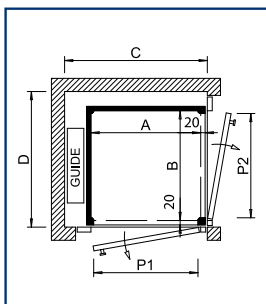

	2AS1	2AS2	
A	795	595	Car
B	795	620	
C	1070	870	Shaft
D	955	780	
P1	750	550	Door
P2	750	575	Door
Kg	250	250	Load

DL-2 P

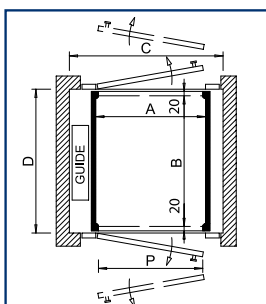

	2PS1	2PS2	
A	800	550	Car
B	800	700	
C	1150	900	Shaft
D	880	780	
P	800	550	Door
Kg	250	250	Load

Aluminium shaft

DL-1 C

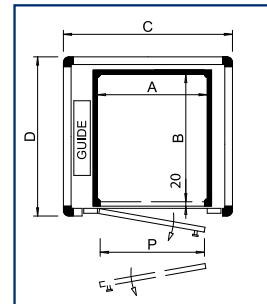

	1CS1	1CS2	
A	800	550	Car
B	800	760	
C	1280	1030	Shaft
D	1020	980	
P	800	550	Door
Kg	250	250	Load

DL-2 P

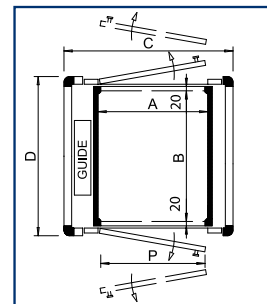

	2PS1	2PS2	
A	800	550	Car
B	800	780	
C	1280	1030	Shaft
D	1000	980	
P	800	550	Door
Kg	250	250	Load

DL-1 L

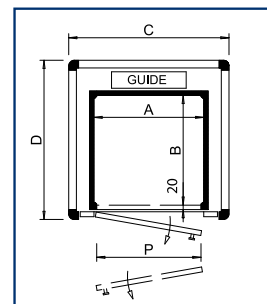

	1LS1	1LS2	
A	800	550	Car
B	800	550	
C	1225	975	Shaft
D	1185	935	
P	800	550	Door
Kg	250	250	Load

Measures stated include an edge of about 5 to 10mm for the door side.



DomusLift® XL

Plenty of space

The **DomusLift XL** series was designed to meet the need for larger cars. Thanks to the maximum of 1100x1400mm, the XL series offers plenty of space and high load.

The special elegant features of the DomusLift range can be further enhanced by:

- all-glass panels (guide rails wall excluded);
- wide range of finishes: plastic, painted or stainless steel laminate.

Also available with two adjacent entrances.

Masonry shaft

DL-1C/XL

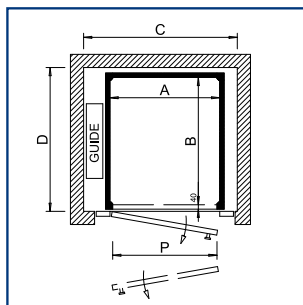

1C/XL	
A	1100 Car
B	1400
C	1500 Shaft
D	1550
P	900 Door
Kg	340/400 Load

Aluminium shaft*

DL-1C/XL

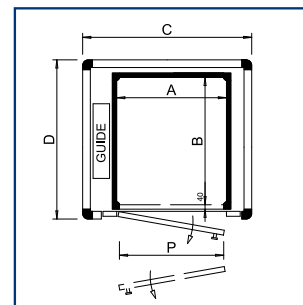

1C/XL	
A	1100 Car
B	1400
C	1630 Shaft
D	1660
P	900 Door
Kg	340/400 Load

DL-2P/XL

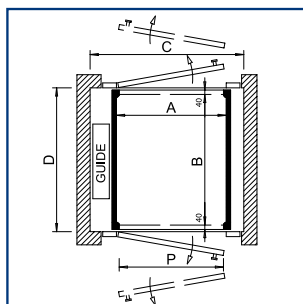

2P/XL	
A	1100 Car
B	1400
C	1500 Shaft
D	1520
P	900 Door
Kg	340/400 Load

DL-2P/XL

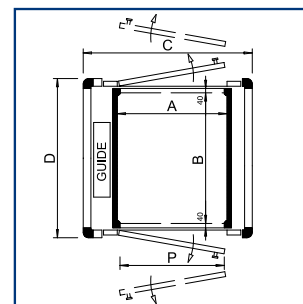

2P/XL	
A	1100 Car
B	1400
C	1630 Shaft
D	1640
P	900 Door
Kg	340/400 Load

Technical data

Travel	15 m max
Pit	120 mm min
Headroom	2500 mm min
Load	400 Kg max (standard model)
Load	600 Kg max (special model)
No. of stops	6 max
Speed	0,15 m/s max
Rated power	2.2 kW for 400kg load models
Jack	1 or 2 pieces

* The aluminium shaft solution of this model must undergo IGV Technical Office's approval.

Maximum car dimensions:

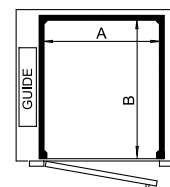

- A** max 1200 mm
- B** max 1500 mm



Cabinet dimensions with power unit and controller:

- 720 x 360 x h. 1500 mm (closed), 720 x 1050 x h. 1500 mm (open) for travels up to 12 m
- 950 x 400 x h. 1850 mm (closed), 950 x 850 x h. 1850 mm (open) for travels > 12 m

Glass car panel available for all car walls (car sling side excluded) and maximum load dimension of 1500 mm.



- Design and manufacture of elevators and hoists
- Company built by eng. Giuseppe Volpe
- 20,000 square metres of factory space
- More than 200 employees

Other products:

- Elevators and goods lifts
- Stairlifts with chair and platform
- Pantograph platform for small rise up to 2m

certified by:



member of:



IGV Group SpA

Via Di Vittorio, 21
20060 Vignate, Milan - Italy
Tel. +39 02 951271
Fax +39 02 9560423
www.igvlift.com
www.domuslift.com

Lifts since 1966

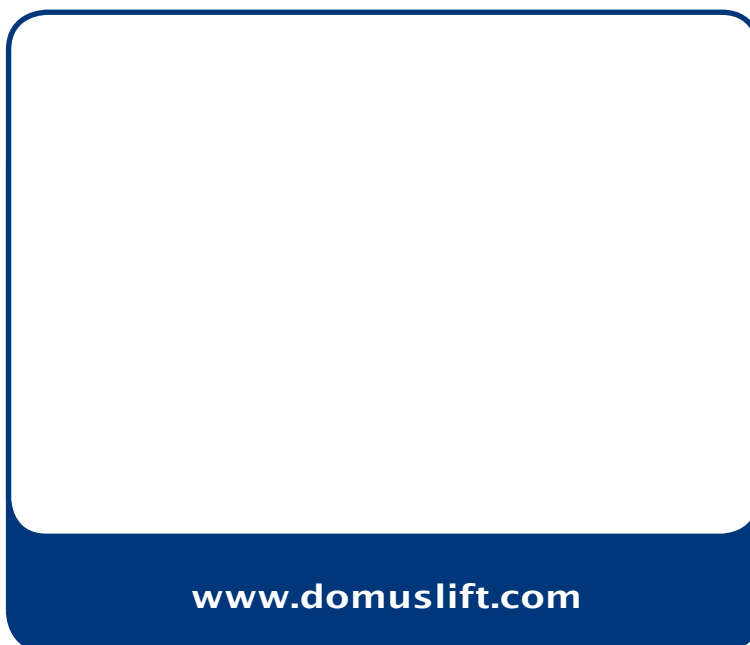

www.domuslift.com